

AMERICAN RANGE

QUALITY PROFESSIONAL COOKING EQUIPMENT

LEGACY SINGLE GAS WALL OVEN

LEGACY SINGLE GAS WALL OVEN FEATURES

- Precision controls over a dynamic range of temperatures from 200°F - 500°F
- Innovation Technology increases turbulent airflow around the oven helping promote more even baking patterns
- Independently controlled heat and fan modes
- Convection Roast perfect for proteins
- Standard Roast mode
- Inconel[®] Banquet broiler provides rapid searing at 1,600°F using 18,000 BTUs.
- Oven Indicator lights indicate when oven is in operation.
- Simplified control panel to ensure ease of use and quick access to oven features, modes, and operations.



AROFG-30
SHOWN IN STAINLESS STEEL, AVAILABLE IN ANY RAL COLOR

The American Range Legacy Series Wall Oven has helped revolutionize the residential culinary luxury experience. Designed with the user in mind, this oven excels in all areas of the cuisine and culinary experience. It's simple, sophisticated design will look great in any kitchen and is available in hundreds of colors to ensure that it can be the accent or focal point of any well designed kitchen. It's simple control interface makes it fast and easy to operate and set to any mode you like and ensures that you maintain exact control for exactly what you need. Say, "Hello" to the American Range Legacy Series Wall Oven!



www.AmericanRangeResidential.com

© Copyright 2018 American Range
All Rights Reserved

LEGACY SINGLE GAS WALL OVEN FEATURES

- NEW Heavy Duty Stainless Steel Brushed Knobs
- Innovation[®] Convection Bake
- Infrared Broil and Fan mode
- Standard & Convection provide a range of 200°F - 500°F
- 6 cooking levels with heavy chrome side supports.
- Porcelainized oven interior simplifies cleaning.
- Extra-large viewing window in oven door.
- 2 lights in each oven are controlled from front panel switch
- Easy to use controls
- Commercial grade stainless steel construction
- Classic Chef Door or commercial-style French Doors improve oven access.
- French oven doors open 130° with the pull of one handle.
- Indicator Lights indicate oven function.
- Inconel[®] Banquet broiler provides rapid searing at 1,600°F using 18,000 BTUs.
- Quick Preheat times and uniform cooking temperatures are created with a 30,000 BTU Bake Burner.
- Lower oven of gas double models features Proofing Element Burner for bread making and low temperature dehydrating.

SINGLE WALL OVEN	
Fuel Type	Gas
Overall Width	30"
Overall Height	31-3/4"
Overall Depth:	
To the edge of control panel	26-1/2"
With French Door open	39-1/8"
With Chef Door open	45-1/4"
Cutout Width	28-1/2" minimum
Cutout Height	31-3/8" minimum
Cutout Depth	24-1/2" minimum
Gas Requirements	7" W.C. Natural, 11" W.C. Propane
Electrical Requirements	120 VAC 15 AMP 60 Hz Single Phase
Oven	30,000 BTU
Broiler	18,000 BTU
Total Connection	30,000 BTU
Approximate Shipping Weight	304 Lb.

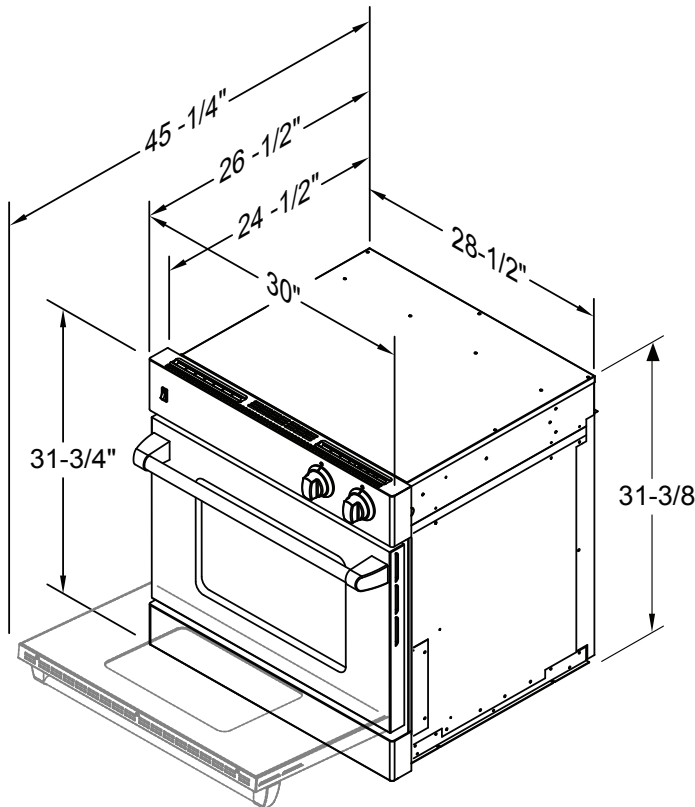

DROP DOWN / CHEF DOOR

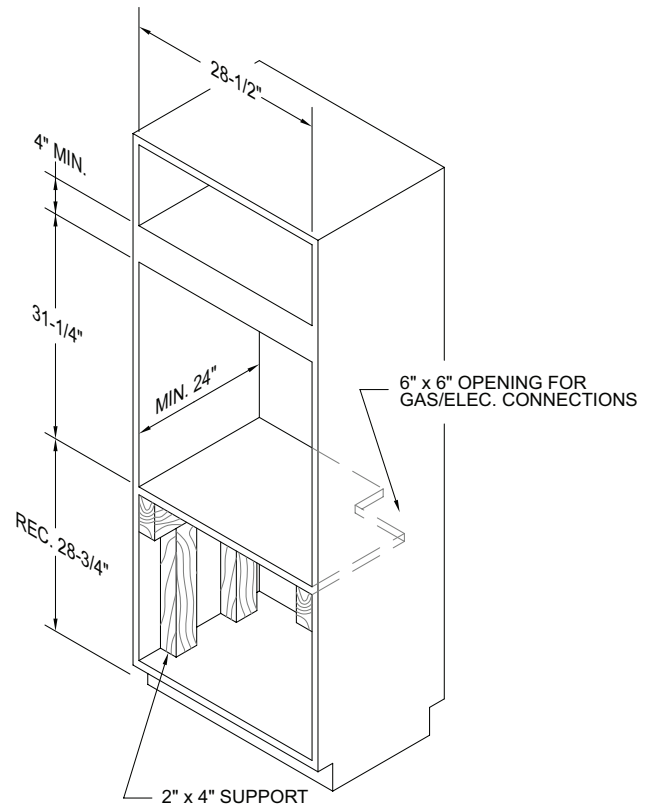

www.AmericanRangeResidential.com

© Copyright 2018 American Range
All Rights Reserved

08302018 Rev A